

NL-33 AUTO User manual



Copyrights

© 2011, Thermopatch bv, Almere, The Netherlands. No part of this publication may be reproduced by any means without the prior written permission of Thermopatch bv, The Netherlands.

Thermopatch and the Thermopatch logo, Thermosteel and Thermocrest are registered trademarks of Thermopatch.

Preface

Dear user,

Welcome to the growing group of Thermopatch users. The product you have purchased has been carefully designed and manufactured to ensure that you, the user, will gain the maximum benefit.

All Thermopatch products are specifically designed to ensure ease of use with particular attention to safety requirements.

Should you discover any fault or damage upon receipt of this product, you should immediately contact your local Thermopatch establishment.

Table of Contents

Preface	3
EC-Declaration of Conformity	5
I. Introduction	6
1.1 WHAT DID YOU RECEIVE?	6
1.2 YOUR SUPPLIER	6
1.3 SPECIFICATIONS OF THE THERMOSEAL NL-33 AUTO	6
1.4 SAFETY	8
1.5 CONDITIONS OF WARRANTY AND PRODUCT LIABILITY	8
II. Installation	9
2.1 INSTRUCTION FOR HANDLING	9
2.2 INSTALLING AND CONNECTING THE NL-33 AUTO	9
2.3 ASSEMBLY	9
III. Operating the NL-33 AUTO	10
3.1 STARTING UP	11
3.2 SAFETY	11
IV. Use of the machine NL-33 AUTO	12
4.1 INSTRUCTIONS FOR THE RUNNING CYCLE	12
V. Press Setting	13
5.1 TEMPERATURE SETTINGS / PRESSING TIME	13
a) TEMPERATURE SETTING	13
b) TIME SETTING	13
5.2 PRESSURE ADJUSTMENT	13
5.3 BOARD PARAMETERS	13
5.4 PRESS HEAD ROTATION SPEED ADJUSTMENT	15
VI. Machine layout	16
VII. Electric and Pneumatic Diagram	17
VIII. Service	18
8.1 PARTS SUBJECTED TO WEAR AND TEAR	18
8.2 REPLACEMENT OF WORN PARTS	19
8.3 MAINTENANCE	19
8.4 ERROR CODE LISTING	20
8.5 POSSIBLE BREAKDOWNS	21

EC-Declaration of Conformity

We,

Thermopatch B.V.
Draaibrugweg 14
1332 Almere
The Netherlands

herewith declare, on our own responsibility, that the machinery: marking machine Thermopatch Thermoseal **NL-33 AUTO**, which this declaration refers to, is in accordance with the conditions of the following Directive(s):

2006/42/EG (Machinery directive)
2004/108/EG (EMC directive)

The Netherlands, Almere, 01-07-2011

Jan Bausch,
Director

I. Introduction

1.1 WHAT DID YOU RECEIVE?

The Thermoseal NL-33 AUTO has been packed in a wooden crate and fixed to a pallet. The following items are included:

- Thermoseal NL-33 AUTO heatsealmachine
- Water condenser and pressure regulator
- Foot pedal
- Power cord
- CD with manual
- CE declaration of conformity

If one or more of the above are missing, please contact your Thermopatch supplier.

1.2 YOUR SUPPLIER

Please look at our website, www.thermopatch.com to find your supplier.

E-mail: sales@thermopatch.nl

1.3 SPECIFICATIONS OF THE THERMOSEAL NL-33 AUTO

The pneumatic machine Thermoseal NL-33 AUTO is practical and universally applicable. It can be used to apply patches, textile emblems, heat seal transfers, in short all Thermopatch materials suited for marking and mending of textiles and technical fibres.

The Thermoseal NL-33 AUTO is to be operated with the fitted foot pedal. Temperature, time and pressure are presented on the display and can be adjusted.

The Thermoseal NL-33 AUTO has been manufactured in accordance with the European guideline for Machines, 2006/42/EC and the EMC guideline 2004/108/EC. This is declared with a general declaration added to this manual and uniquely serial number based to this machine.

Specifications

Weight in running order	107 kg
Height	562 mm
Depth	750 mm
Width	977 mm
Dimension of the heating plate	400 x 450 mm
Electric power supply	230 V single phase + ground 50/60 Hz
Pneumatic power supply	10 bars maximum
Power	2500 W
Ampere	11 A
Thermoregulator	
Accurate to	±1%
Range of control	0 to 250°C
Working pressure (Min-Max)	2-8 bar
Pressing effort	765 DaN
Timer	
Accurate to	±1%
Range of control	0 sec. to 30 min

Attention!

To obtain the required sealing pressure, the NL-33 AUTO has to be connected to a compressor with a working pressure of at least 6 bars. The air has to be clean and dry.

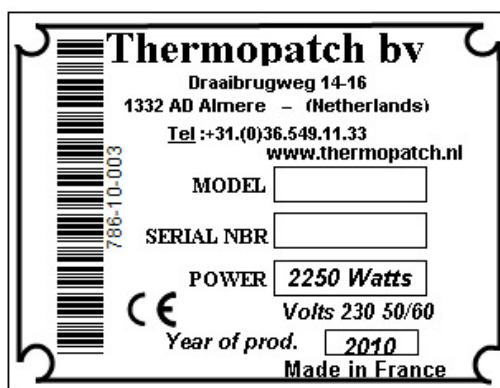

1.4 SAFETY

At normal usage no problems are to be expected. Regardless that, we state underneath a few pointers which will limit existing risks to a minimum.

- Unplug the machine from the wall socket whenever you are maintaining or cleaning the machine.
- Make sure there is enough working space around the machine. Although the heat radiation of the press is very low, it is still necessary to have enough room for cooling down. Extensions and connections must not get snagged.
- Avoid contact with the press arm and the heating element.
- Pull the fabric tightly over the sealing pad.

1.5 CONDITIONS OF WARRANTY AND PRODUCT LIABILITY

Thermopatch points to its warranty and product liability conditions as laid down in our sales conditions. These can be obtained at your Thermopatch supplier.

II. Installation

2.1 INSTRUCTION FOR HANDLING

The NL-33 AUTO has been packed in a wooden crate and fixed to a pallet. If you need to relocate the machine at a later point, we advise you to pack the machine in a similar fashion. Let the machine cool down completely before packing and moving it.

2.2 INSTALLING AND CONNECTING THE NL-33 AUTO

Take the Thermoseal NL-33 AUTO from its box and place it on a stable worktop near an earthed wall socket. Connect the machine with the supplied power cord to the electrical current (230 Volt, alternating current). The NL-33 AUTO is earthed and provided with a fuse (11 Amps).

2.3 ASSEMBLY

To ensure a problem-free operating of your NL-33 AUTO, it is essential to work with dry, clean compressed air. The supplied pressure regulator with water condenser is only an added protection of the machine. The user has to make sure that the pressure on the machine does not exceed 6 Bars. Connect a 6 mm air tubing with the compressor or the local compressed air system and connect this subsequently to the water condenser / pressure regulator mounted on the NL-33 AUTO. The NL-33 AUTO is fitted with a foot pedal for its operation. Connect the foot pedal by inserting the connector into its slot, which is placed underneath power entry on the back of the machine. Fasten the securing ring after inserting the connector.

III. Operating the NL-33 AUTO

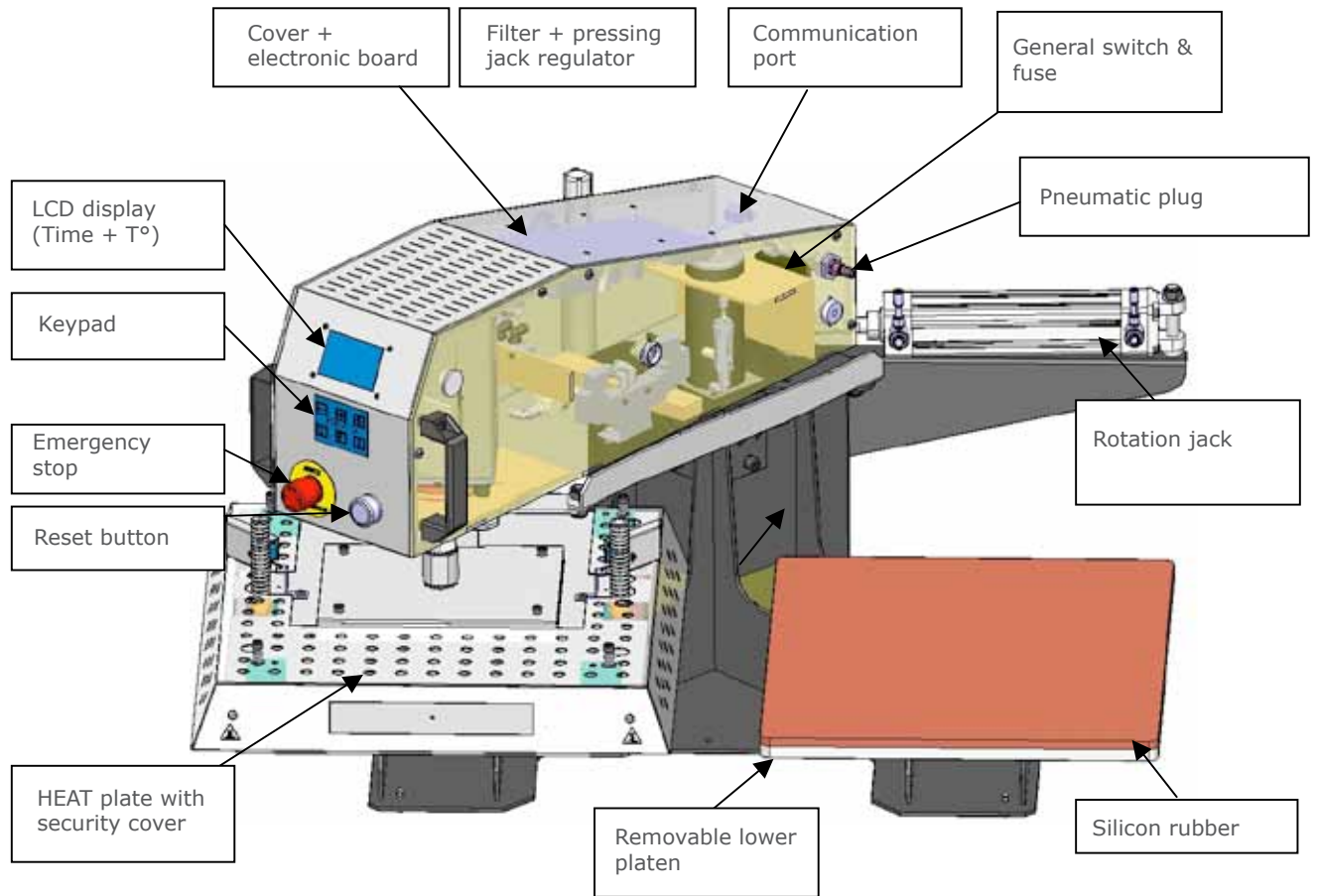

3.1 STARTING UP

You can start operating the NL-33 AUTO as soon as it is connected to the electricity mains. Set the air pressure. Take note of the conditions and working instructions as stated in Chapter 2. Switch on the NL-33 AUTO by pressing the on/off (I-0) switch, which is placed on the left side of the machine, to "On (I)". Wait until the set temperature has been reached, approximately 20 minutes.

3.2 SAFETY

- The machine has been designed for single use only.
- Please take note of the contents of this manual.

Please follow below safety guidelines:

Avoid touching the hot parts of the equipment while in use. Do not put your hands between the plates once the NL-33 AUTO is activated. Carry out a daily inspection of the machine before starting the production. Make sure to keep the direct surroundings of the machine free from unauthorized personnel while operating it.

When the machine malfunctions, please switch off the power supply and refer to the manual's chapter "Service".

Do not modify the safety devices and protective measures that have been provided on this machine. Make sure these are reinstated as intended, after maintenance or repairs.

IV. Use of the machine NL-33 AUTO

4.1 INSTRUCTIONS FOR THE RUNNING CYCLE

1. Power the machine up by using the on - off switch which is on the left hand side of the machine.
2. Check if the screen light is on. After a welcome message, it will show the factory settings.
3. Set the temperature with the keyboard (to be defined by applied product and underlying textile), See Chapter V. PRESS SETTING § 1.
4. Set the application time with the keyboard See V. PRESS SETTING § 1.
5. Set the pressure by adjusting the air filter pressure regulator. See V. PRESS SETTING § 2.
6. Place the article on the lower plate.
7. Place the transfer or emblem.
8. Activate the NL-33 AUTO by pressing the foot pedal.
9. As soon as the press head is in position it will lower onto the lower platen and the timer will count down.
10. Prepare other lower platen with the next to be marked textile item and transfer or emblem.
11. At the end of the timer count down, the press head will go up again.
12. Press the foot pedal again (if not on "with full auto" mode, see §V-3).
13. Remove the article from the first position and prepare the next item here.
14. Start the operation again from no. 9 (if the settings are left unchanged, otherwise start from no. 3 again).

V. Press Setting

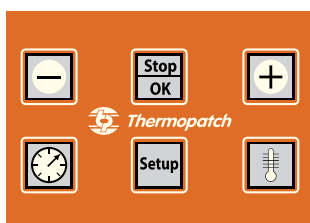

5.1 TEMPERATURE SETTINGS / PRESSING TIME

These parameters have to be programmed in the control electronic card with the keyboard situated on the front (the parameters will scroll on the display unit next to it).

- a) TEMPERATURE SETTING
 - Press on "Temperature",
 - Press on "-" to decrease the indicated value, or on "+" to increase it,
 - Press on "OK" to validate your choice.

- b) TIME SETTING
 - Press on "Time",
 - Press on "-" to decrease the indicated value or on "+" to increase it,
 - Press "OK" to validate your choice.

5.2 PRESSURE ADJUSTMENT

The jack pressure can be modified according to the user's need.

Use the pressure regulator situated on the filter, on left side. The pressure will appear on the front manometer's dial. Pull the regulator's head upwards, then turn:

- clockwise to increase the pressure,
- anticlockwise to decrease the pressure.

5.3 BOARD PARAMETERS

Press on "Set up" key to enter parameters, "+" to scroll parameters, "OK" to enter in and validate, "Set up" to exit.

"Set up" > 2PLATEAUX > program (T°+s) > resetable counter > permanent counter > pre-heating > standby > code

PREFERENCES SET UP:



- ☐(⊕+ ⊕) ^{OK}➤ Press + to scroll programs (P1 to P5)
press ⊕, + or - to modify preheating time, OK
press + or - to modify time pressure, OK
press ⊕ to modify temperature, OK

NOTE: the selected program at start will be the edited one in parameters. You need to enter in parameters to change and keep the new program.

TO SET UP RESETABLE COUNTER:

  → press - > reset counter > press OK (or Set up to cancel)

TO SET UP PERMANENT COUNTER:



  : not modifiable

TO SET UP PRE-HEATING:

  → press OK, then + to modify ON/OFF

Note: pre-heating time will be able only if pre-heating parameter is ON.



TO SET UP STANDBY:

  : press  to modify > + activate (ON) > OK > + to modify standby temperature, OK > + to modify start standby time > OK > + to modify wake-up time

CODE : press OK to enter a code, + for next digit, ok to confirm and swap to next.

100 : time setting :  to enter in, + to modify, OK to confirm

300 :   > ok to enter in offset temperature setting >  to modify offset > +/- to change value.

 > ok to enter in ALARM parameters at end cycle >  to modify > +/- to change value.

 °C/°F > ok to modify temperature UNIT > + to modify > ok to confirm > Set up > Set up to exit.



Adr. MODBUS : > ok to see communication port (switch on board).

DETAIL OF THE FULL AUTO OPTION :

If you have this option, you can change the cycle of the machine.

- Normal Mode : After you push the pedal, the press platen moves to the other plate and press.
- One plate mode : After you push the pedal, the press platen moves to the other plate, press and come back to its starting plate.
- Automatic mode : After you push the pedal, the press platen moves to the other plate and starts the heat sealing cycle. At the end of the « sealing timer » it automatically switches platens and heat seals again. This will continue until you push the pedal or the touch OK/ STOP, which will end the automatic cycle.

Choice of Functioning mode :

Push Set up --> (2 PLATES) --> OK -->   --> +-->OK

 : push "+", to activate « YES », or deactivate « NO », the AUTOMATIQUE mode. Push on OK to validate your choice and pass to the next parameter.

1P : push "+", to activate « YES », or deactivate « NO », the ONE PLATE mode. Push on OK to validate your choice.

If the automatic mode and the one plate mode are deactivated, the machine will run in normal mode.

Push 3 times on Set up to go back to the main screen.

Regulation of « the timer after pressing » : used only in automatic mode:

Push Set up --> (2 PLATES) --> OK -->

⊕ ⊖ : Push on OK, the time's flashing, use the + or – touches to modify it. Push OK to validate the new entry.

Push twice on Set up to go back to the main screen.

5.4 PRESS HEAD ROTATION SPEED ADJUSTMENT

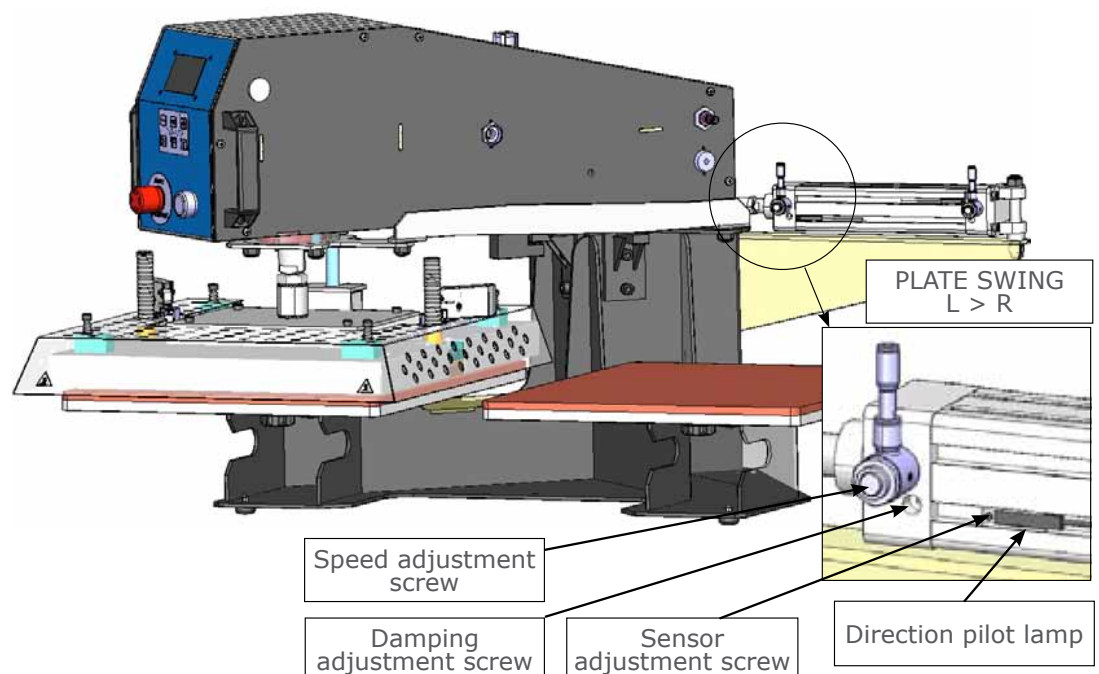

By means of a screwdriver, periodically adjust the swinging speed. It varies as a function of lubrication and wear of mechanical parts.

- ⌚ clockwise to reduce
- ⌚ counterclockwise to increase

If the plate bounces before/after sealing, reduce the damping (hex wrench)

- ⌚ clockwise to reduce
- ⌚ counterclockwise to increase

VI. Machine layout

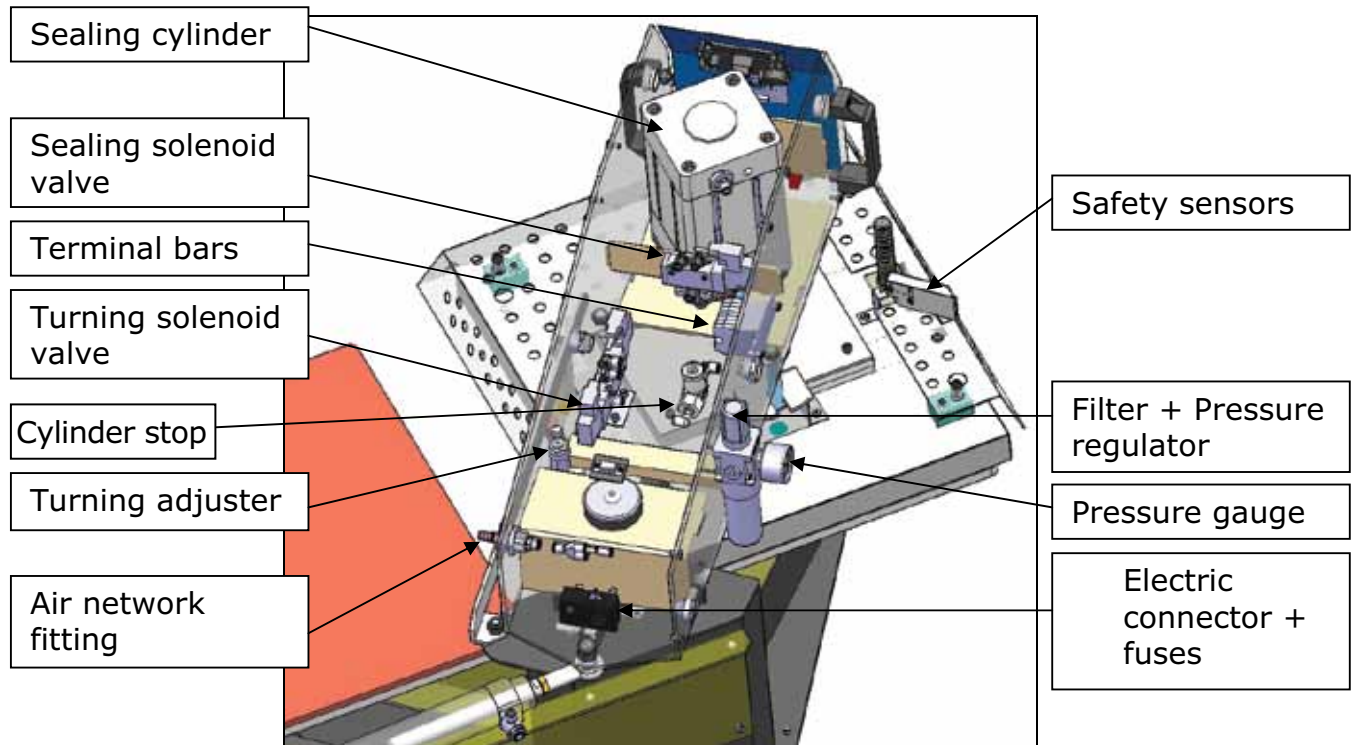

NOTE: The electronic board is under the cover, removed above

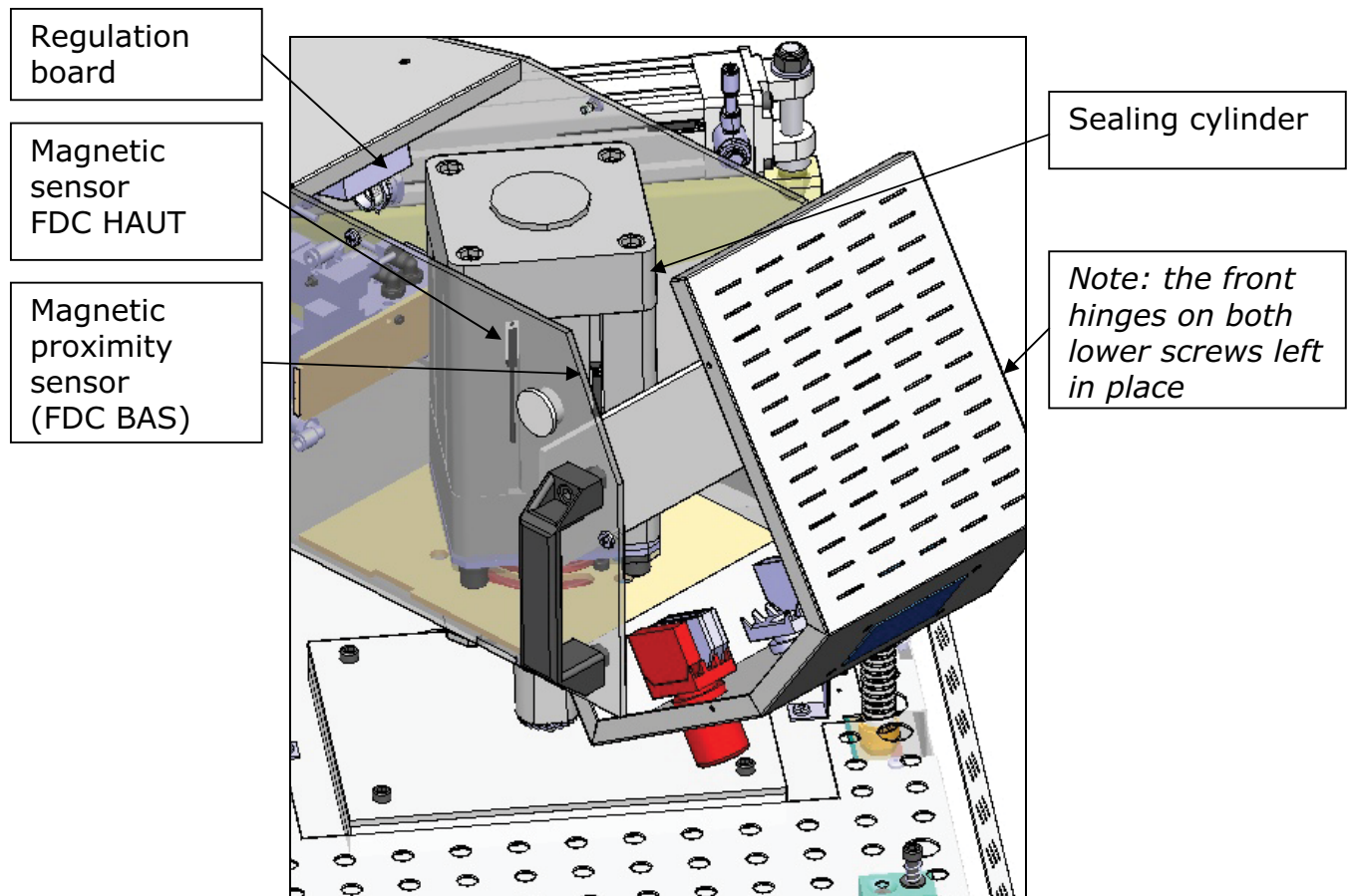

VII. Electric and Pneumatic Diagram

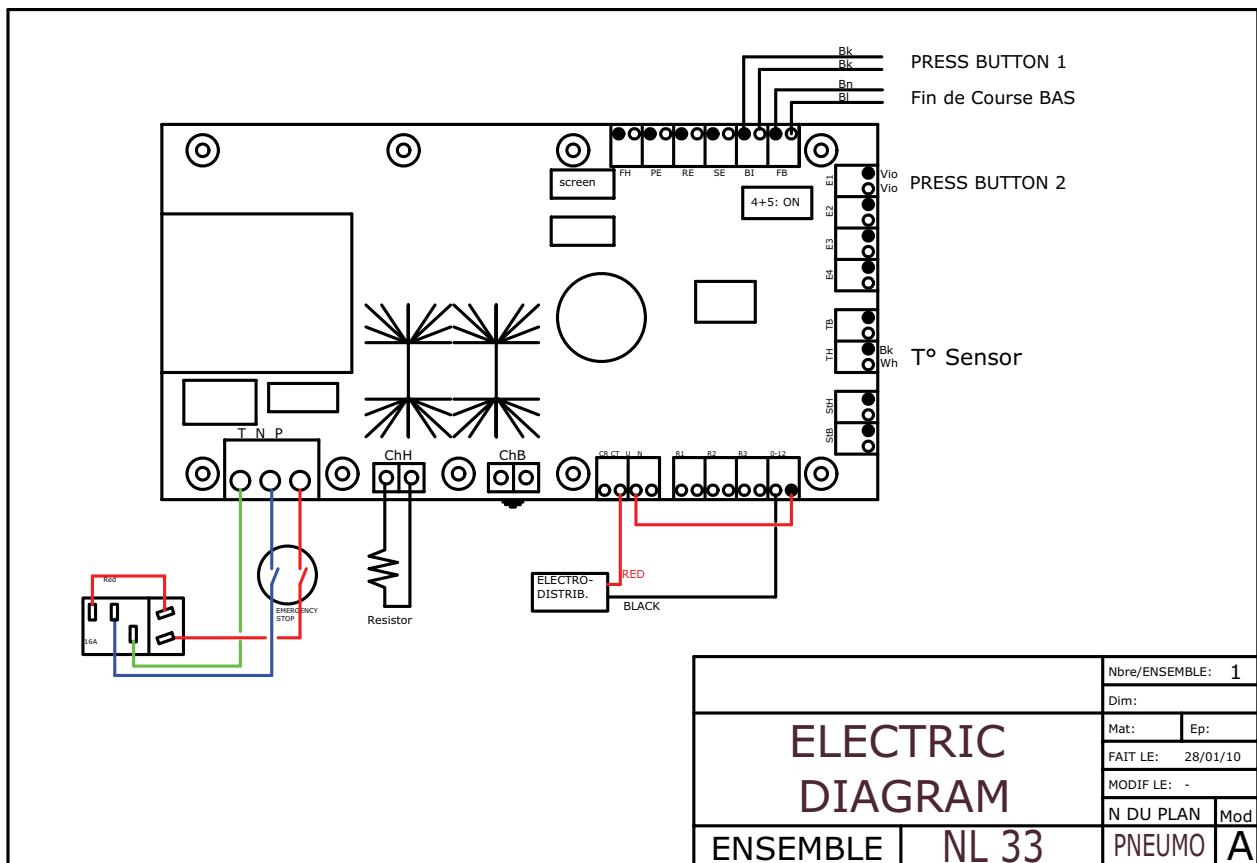
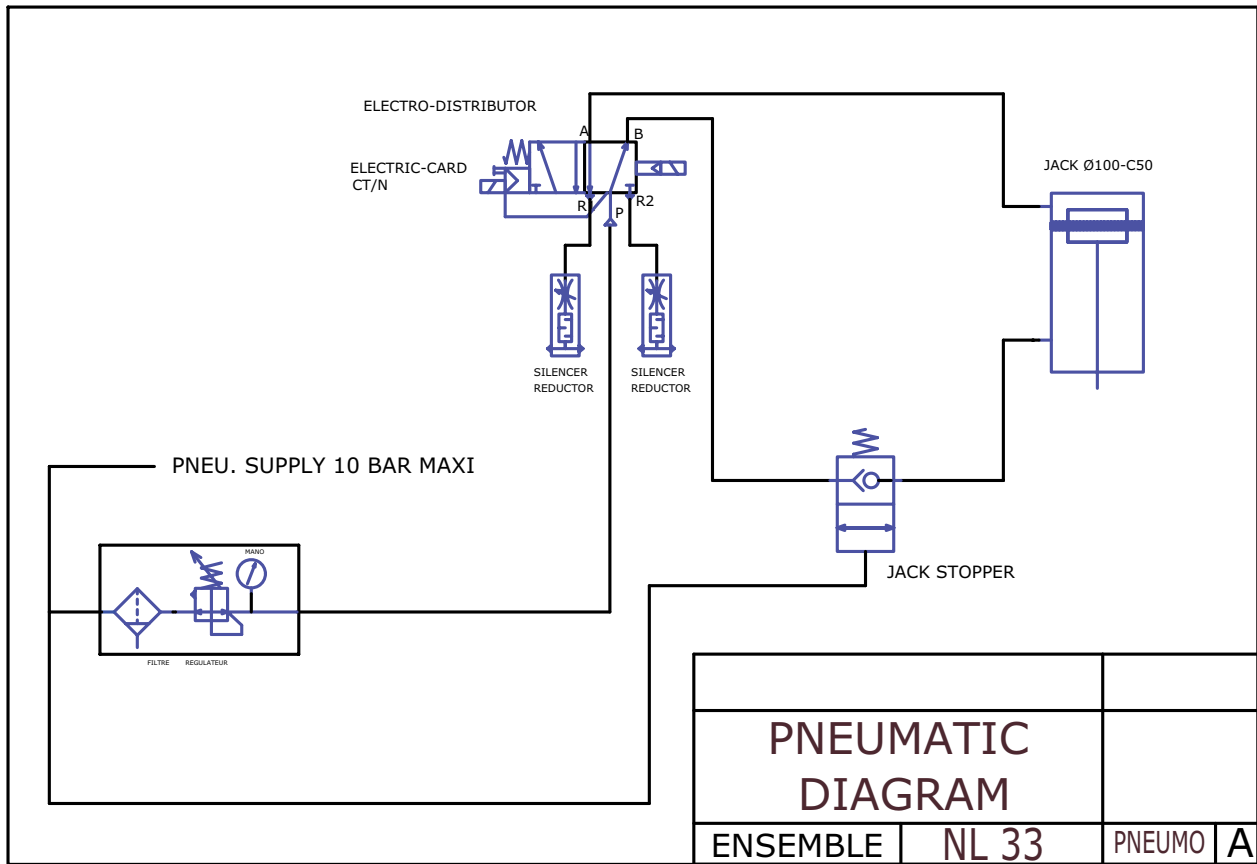

VIII. Service

UNPLUG THE MACHINE FROM THE ELECTRICITY AND AIR SUPPLY BEFORE SERVICING!

It is recommended to have the following tools within reach:

- Phillips - and bit screwdrivers;
- A set of end wrenches and box spanners;
- Small adjustable pliers;
- Circlip pliers;
- Long and fine pliers with insulating handle;
- A set of Allen keys;
- A multimeter.



Before any handling, check that the heating plate temperature is lower than 25°C on the display unit.

8.1 PARTS SUBJECTED TO WEAR AND TEAR

On any order: state the reference, the description and the quantity.

Reference	Description	Quantity
ELECTRIC PARTS		
SPA33-001	Regulation board	1
SPA3X-001	Back-Lighted Screen	1
SPA3X-014	Keypad	1
SPA3X-020	Mica resistor 430x380 P.2250W	1
SPA3X-003	Fuse 5x20mmT 16 A 250V	2
PNEUMATIC PARTS		
SPA3X-010	Jack Ø100 C50 (pressing)	1
	Filter & regulator	1
SPA3X-009	Electrodistributor 5/2 G1/8 12v	3
FRAME DRESSING		
	Silicon rubber 9 mm	400 X 450 mm

8.2 REPLACEMENT OF WORN PARTS

- Silicone rubber mat:
 - a) check that the platen is cold.
 - b) make sure that the surface of the platen is quite clean. Possibly use a soft solvent such as White Spirit with individual protections.
 - c) use a tube of glue RTV-1 to stick the rubber to the aluminium platen (NB : read the instructions on the tube packaging).
 - d) the cover and the platen must be clean and dry before you start gluing.
 - e) spread a fine, even coat of glue on the plate and immediately apply the cover making sure that there is no air lock (NB: An indented spatula similar to the one used to lay tiles would suit perfectly).
 - f) leave to settle overnight at room temperature with slight pressure and without heat.
- Other parts:

Get in touch with your supplier to evaluate their change or their repair.

8.3 MAINTENANCE

The heat seal press NL-33 AUTO requires hardly any maintenance. To ensure a good functioning, follow the preventive notice indicated below:

- Do not heat up objects which could deteriorate or even cut the silicone rubber or damage the teflon surface of the heating plate
- Every so often and when the plate is cold, clean the machine with a clean cloth and white spirit (NB: As this product is flammable, use with care and keep it away from any heat source) using personal protection measures.
- When the heating plate is hot and unused, keep it in open position.

EVERY DAY: When still cold, clean the heating plate with a clean, dry cloth.

Check the air filter at the back of the press; drain condensated fluids regularly.

EVERY MONTH: Check the column and apply some grease to it.

ACCORDING TO THE USE: Change the rubber mat every six months.

8.4 ERROR CODE LISTING:

SSH/B	: HEAT SENSOR DEFECT High/Bottom
RRH/S	: RESISTOR out of service High/Bottom
DDD	: Overshoot 30°C of order
CCC	: Fall out of 30°C of order
FDC	: Sensor still activate at end cycle
TRIAC	: TRIAC defect
TIME OUT	: Time out to get temperature order, heating defect

8.5 POSSIBLE BREAKDOWNS

UNPLUG THE MACHINE FROM THE ELECTRICITY AND AIR SUPPLY BEFORE SERVICING!

Symptoms	Possible breakdowns	Repairs
The machine will not switch on	<ul style="list-style-type: none"> The plug is not in. The switch is not connected. The general fuse is out of order. The card fuse is out of order. The display unit is faulty. 	<ul style="list-style-type: none"> Put the plug into the wall socket. Switch the On - Off switch to "ON"(I). It is situated in a casing next to the power cable plug. To access it, pull the power cable out, with the tip of a screwdriver lift the fuse casing. You will find in the square tube a replacement fuse to put instead of the one in the clip. It is situated at the bottom left of the card (1A). Check if the flat cable is properly connected otherwise the display unit is out of order.
The plate will not heat	<ul style="list-style-type: none"> The resistors are defective. Card problem. Temperature value too low. 	<ul style="list-style-type: none"> Check the connections and the state of the electric wiring. To remove the heating plate, get in touch with your supplier. See messages displayed on the screen and refer to the card manual. To modify this value, see chapter V.
The plate overheats	<ul style="list-style-type: none"> Sensor or card problem. 	<ul style="list-style-type: none"> See messages displayed on the LCD screen and refer to the card manual. Get in touch with your supplier.
The timer will not count down	<ul style="list-style-type: none"> The detector placed on a jack is not activated or defective. Card problem. 	<ul style="list-style-type: none"> Check its connections. See messages displayed on the screen and refer to the card manual.
The plate will not go down	<ul style="list-style-type: none"> The push buttons will not work. Leak on the jack. The electrical distributor is faulty. The compressed air pressure is not enough. 	<ul style="list-style-type: none"> Check their connections. Check the joints and all the connections. Get in touch with your supplier. Check its connections. Get in touch with your supplier to possibly change it. Check if the pressure of your network is > 3 bar.
The plate will not go up	<ul style="list-style-type: none"> The electrical distributor is faulty. Leak on the jack. 	<ul style="list-style-type: none"> Check its connections. Get in touch with your supplier to possibly change it. Check the joints and all the unions. Get in touch with your supplier.
The plate stays in lower position after pressing	<ul style="list-style-type: none"> The timer will not count down. 	<ul style="list-style-type: none"> See above.

Thermopatch Corporate Headquarters	USA	T +1 315 446-8110	F +1 315 445-8046	sales@thermopatch.com
Thermopatch European Headquarters	The Netherlands	T +31 36 549 11 11	F +31 36 532 03 98	sales@thermopatch.nl
Thermopatch Australia Pty Ltd	Australia	T +61 395325722	F +386 2 80 55 232	marktpatchaust@bigpond.com.au
Thermopatch Canada Inc	Canada	T +1 519 748-5027	F +1 519 748-1543	broussel@thermopatch.com
Kannegiesser UK Ltd.	United Kingdom	T +44 1539 722122	F +44 1539 721000	thermopatch@kannegiesser.com